

The EDIX is a key access interlock complete with emergency exit system for use on hinged doors. The interlock is manufactured in durable stainless steel and comes with the stainless steel FS or Q lock type portions. Two internal crashbar options are available: a light duty two point aluminium and a heavy duty three point stainless steel. Typical industries using the EDIX are fire protection, turbine and offshore industry.

## OPERATION

Castell dual key access interlocks are used in various applications to control full body access to hazardous areas.

### EDIX dual key access interlock, Hand 1

- 1** Door is locked closed while isolation key is free and personnel key is trapped.

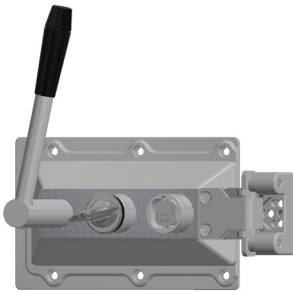

Under normal operating conditions, the isolation key is free, the personnel key is trapped, the catch is retained and the door is locked closed.

- 2** Insert and turn isolation key, then release personnel key and release catch from locking mechanism by operating the handle.

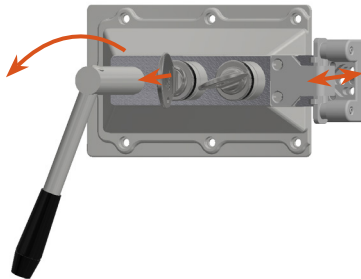

The door can only be opened when the isolation key has been inserted and turned and the personnel key removed. Once the personnel key has been removed, the handle can be operated and the door opened.

The handle is operating the internal crashbar, with the keys simply controlling how the operator gets the door to a condition that will allow access.

- 3** Door is unlocked, isolation key is trapped and personnel key is free.

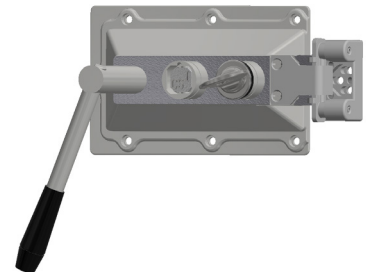

With the door open, the isolation key is trapped within the lock. The internal crashbar will override the external lock at all times making it suitable for the most hazardous of areas.

## USAGE

The EDIX dual key access interlock should be used to allow safe access to potential hazardous and dangerous areas.

The EDIX dual key access interlock should be used on full body access doors where the use of personal safety keys is essential, to prevent accidental lock in.

 The EDIX dual key access interlock is not designed for security purposes, such as access to a building.

No hazardous substances were used in the manufacture of this product.

## INSTALLATION

The housing of the EDIX dual key access interlock should be mounted on the door and the catch to the static frame of the door using suitable fasteners. Fixed bolt bracket is highly tolerant to misaligned doors and should be fitted with suitable fasteners. Please refer to the drawing on page 4 for maximum and minimum mounting distance for the housing, catch mechanism and mounting holes details. The EDIX interlocks are available in Hand 1 and Hand 2 version suitable for left or right hinged doors, respectively.

 **IMPORTANT:** The EDIX dual key access interlock should be mounted on the door using anti-tamper fasteners to prevent unauthorised removal.

 The EDIX dual key access interlock must be installed by a competent and qualified person who has read and understood these instructions. Please retain this document in your technical file.

 Alignment limits of 0.5mm must be set in all planes. Angular displacement  $\pm 1^\circ$  between lock and catch.

 The manufacturer should be consulted when use in a corrosive environment is planned.

## MAINTENANCE

Periodic visual checks should be carried out by the site manager/safety officer.

Do not lubricate lock barrel with oil or grease, use CK dry powder graphite if necessary.

 In case of defects being detected please contact your nearest Castell Support Department for further actions. Please see Contact section for contact details.

 The interlock must be inspected every 6 months. Safety checks should include ensuring the keys can only be removed in the correct safety operating conditions (see page 1).

## TECHNICAL DATA

<b>Temperature rating</b>	Minimum: -40°C [-40°F] ice free for Q & FS lock type
	Maximum: 107°C [224.6°F] for Q lock type/140°C [284°F] for FS lock type or 288°C [550°F] upon request
<b>Type of mounting</b>	Surface mount using suitable fasteners (see drawing on page 4 for mounting details)
<b>Weight</b>	Stainless steel: 14.0 kg
<b>Material</b>	Stainless steel
<b>Shock &amp; vibration</b>	In accordance with BS EN 50155 & IEC 61373
<b>PL rating</b>	PLd
<b>B10d</b>	1,200,000

## APPLICATION

The EDIX safety component is used as a part of an integrated safety system to guard personnel when working within an area protected by a CO<sub>2</sub> extinguishing system.

The safety system involves a KS key switch for the electrical supply to the extinguishing system controlling its operation mode. The removal of the key from the key switch changes the mode of the extinguishing system from automatic to manual. This key is then inserted in the MBV modular ball valve interlock fitted to the CO<sub>2</sub> valve. With the key inserted, the valve is turned to the closed position, preventing the extinguishing system from being activated and allowing the removal of the secondary key from the MBV. This key is then inserted into the isolation lock on the EDIX and the personnel key removed. The door can now be opened by operating the handle. The personnel key is taken into the area by the operative. This prevents the ability of others to re-energise the extinguishing system while maintenance is being performed.

In case of an emergency the EDIX door lock can be overridden from the inside using the emergency exit crash bar.

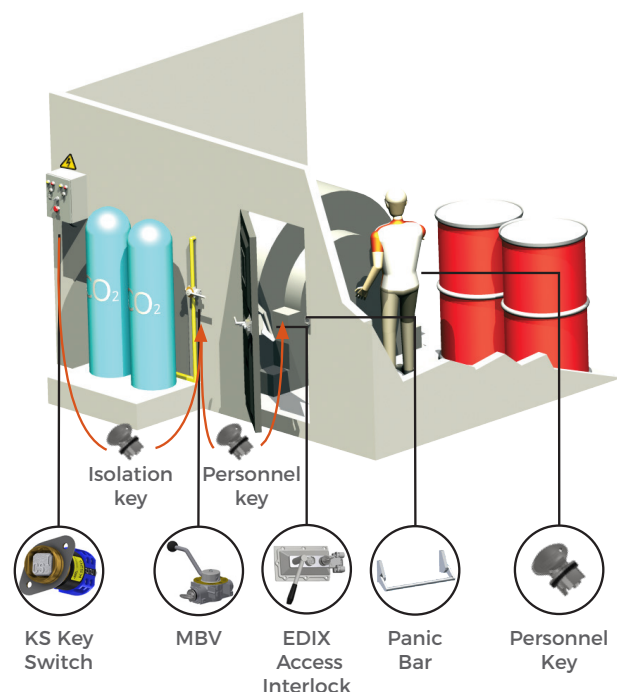

## EC-DECLARATION

We, the manufacturers, declare that the components detailed herein and placed on the market comply with all the essential health and safety requirements applying to them.

ISO 13849-1:2015 Safety of Machinery

2006/42/EC Machinery Directive

Empowered signatory:

Kirstie Van Oerle  
Business Unit Director 

## DRAWING

Dimensions: in mm

**Note:** For safe mounting, use security screws

### EDIX, Hand 1

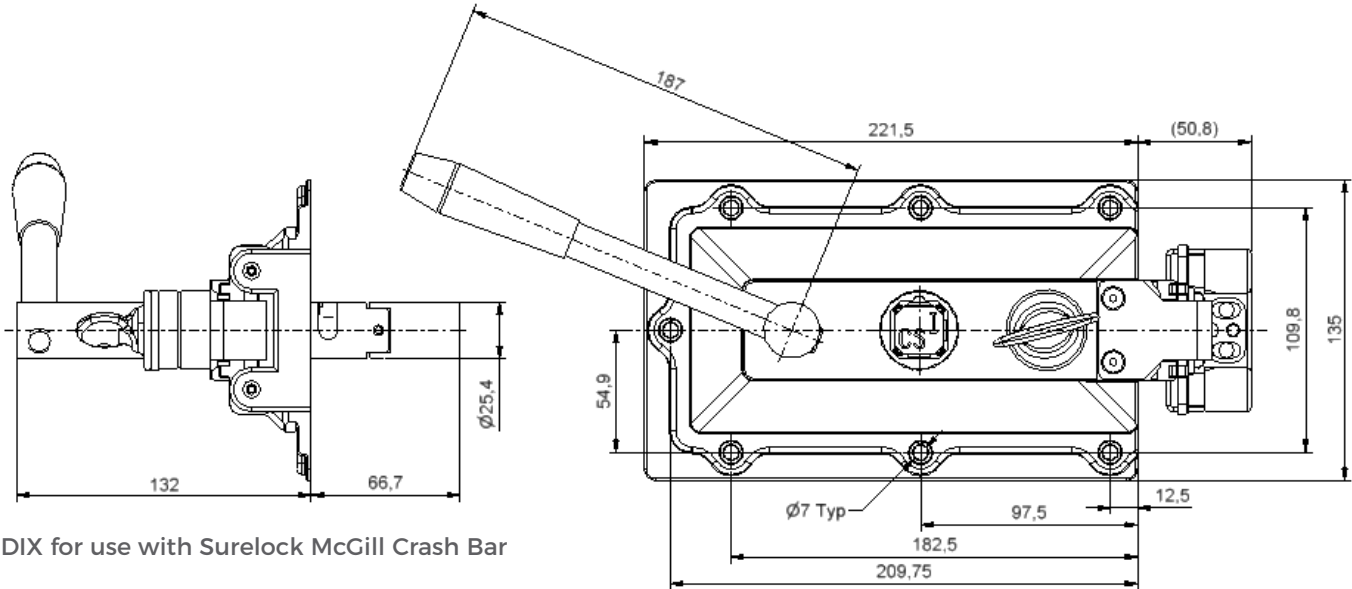

EDIX for use with Surelock McGill Crash Bar

### EDIX, Hand 2

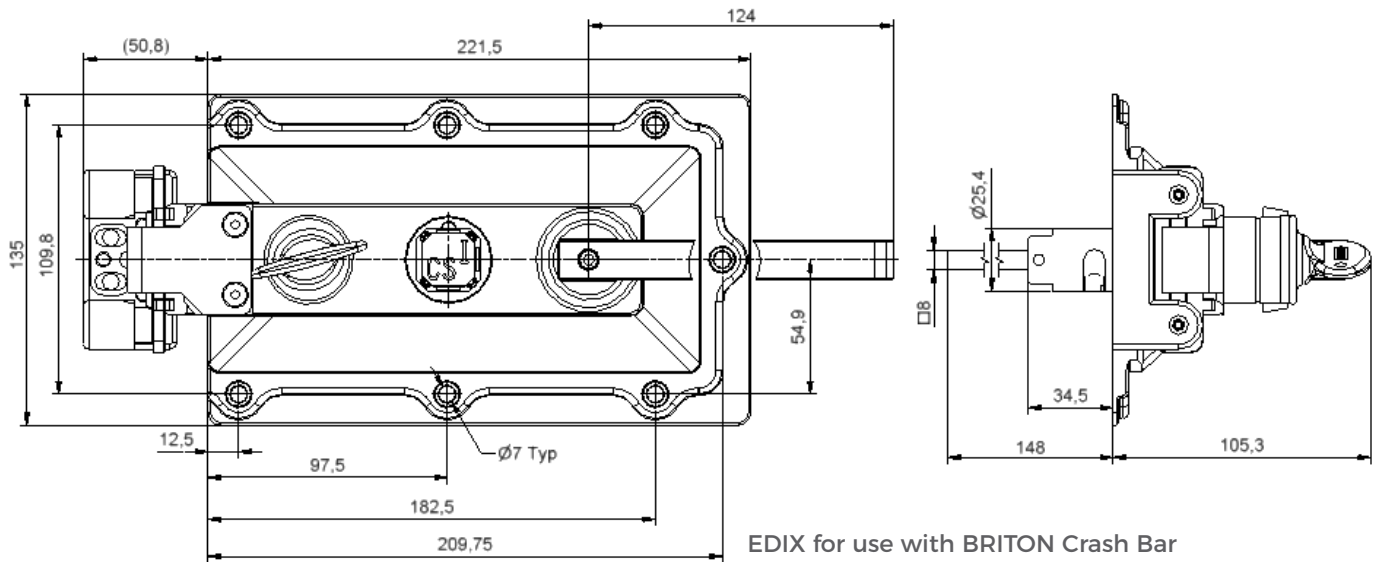



EDIX for use with BRITON Crash Bar

## ORDER INFORMATION

	<b>Component type</b>	<b>1</b>	<b>2</b>	<b>3</b>	<b>4</b>	<b>5</b>
Part number	EDIX					
Example	EDIX	FS	S	BRI	1	TBA

<b>1</b>	<b>Lock portion type</b>	FS (1) / Q (1)
<b>2</b>	<b>Material</b>	S = Stainless steel, standard
<b>3</b>	<b>Crash bar type</b>	SUR = SURELOCK McGill crash bar BRI = BRITON crashbar
<b>4</b>	<b>Handing</b>	1 = Left hinged door (1) 2 = Right hinged door (1)
<b>5</b>	<b>Lock portion symbol:</b> Please advise for each lock portion separately as isolation key/lock symbol and personnel key/lock symbol	FS (1) up to 3 characters / Q (1) up to 6 characters

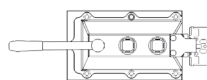
(1)	<b>FS - Lock type</b> Up to 3 characters	<b>Q - Lock type</b> Up to 6 characters	(2)	<b>Handing</b>
				<b>1</b> 

Special construction available upon enquiry

## CONTACT INFORMATION

### Castell Safety

The Castell Building  
217 Kingsbury Road  
London, NW9 9PQ  
UK

t: +44 (0)20 8200 1200  
f: +44 (0)20 8205 0055  
e: [sales@castell.com](mailto:sales@castell.com)

### Castell Safety

Tower 185  
60185 Frankfurt am Main  
Germany

t: +49 (0)69 50 50 47 310  
f: +49 (0)69 50 50 47 450  
e: [vertrieb@castell.com](mailto:vertrieb@castell.com)

### Kirk Key Interlock

9048 Meridian Circle NW  
North Canton, OH 47720  
USA

t: +1 800 438 2442  
f: +1 330 497 4400  
e: [sales@kirkkey.com](mailto:sales@kirkkey.com)

### SPS China

2F, Building 63  
No 421 Hongcao Road, Xuhui District  
Shanghai PRC, 200233  
China

t: +86 (0)21 6040 7398  
f: +86 (0)21 5453 0630  
e: [chinasales@castell.com](mailto:chinasales@castell.com)